

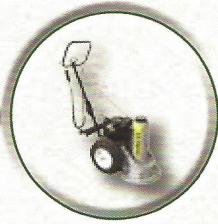

Positioning & Lifting Equipment Specialists



POW'R RISER

Heavy Duty, Off Road Equipment & Railcar Lifting

JE6024 SHOWN

SEE TABLE FOR ADDITIONAL MODELS

- ✓ 24", 26" & 37" Minimum Heights
- ✓ 60, 100, 150 & 200 ton capacities to handle the toughest jobs
- ✓ 3 position handle for easy tilt back and rolling
- ✓ 4" of ground clearance for rough terrain
- ✓ Easy to change external filter minimizes down time
- ✓ Standard 12' pendant cord for air driven units and 20' pendant cord for electric driven keeps the operator away from the load during operation
- ✓ Dual hydraulic locking systems prevent creep down
- ✓ Equipped with a pilot-operated check valve which locks the load in place
- ✓ Optional Extension System and Mechanical Lock Rings are available



For over a century, Simplex has been known throughout the industry for its industrial positioning equipment capabilities. The POW'R RISER is of no exception to that fact.

The heavy duty POW'R RISER comes equipped with a 12' pendant cord for air driven units and a 20' pendant cord for electric driven units. Available in 60, 100, 150 & 200 ton capacities to handle the toughest jobs and only 24" wide, the Simplex POW'R RISER is the only choice for extensive, large capacity lifting applications.



NOTHING ELSE COMES CLOSE:

- Rugged, fully enclosed frame; no exposed fittings or hoses
- Runs on air, 115VAC/15 amp, 230VAC/10, or 230/460VAC 3 phase service
- Secondary back-up filtration system for reliability.
- Light weight for greater mobility and less back strain
- Automatically controlled, "chatter free" load lowering for maximum safety in descent
- All Pow'r-Riser models comply with ASME/ANSI B30.1 Specifications

POW 'R RISER

Heavy Duty, Off Road Equipment & Railcar Lifting

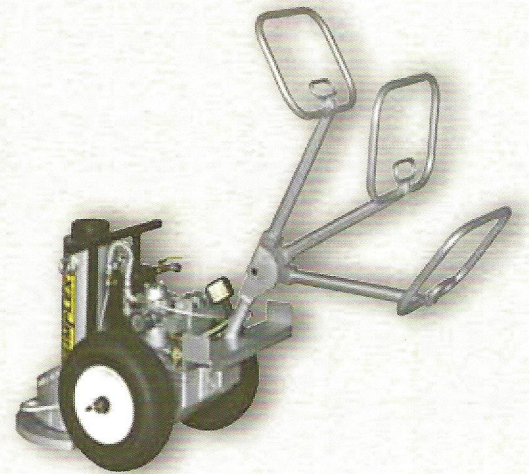

JAS10026 SHOWN
SEE TABLE FOR ADDITIONAL MODELS

IDEAL FOR LIFTING APPLICATIONS SUCH AS...

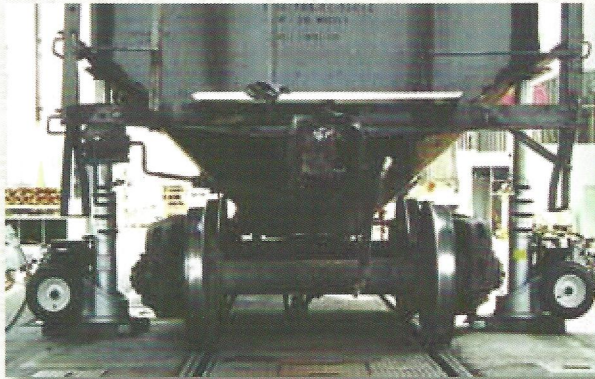

Rail Yard



Off Road / Mining

| Product Dimensions | | | | |
|--------------------|-------------|-------------|-------------|-------------|
| Model | "A" (in) | "B" (in) | "C" (in) | "D" (in) |
| JE6024 | 24 | 6.38 | 14 | 4 |
| JE6037 | 37 | 6.38 | 14 | |
| JE10026 | 26 | 7 | 18 | 4 |
| JE10037 | 37 | 7 | 18 | |
| JE15026 | 26 | 8 | 18 | 5 |
| JE15037 | 37 | 8 | 18 | |
| JAS20026 | 26 | 10 | 18 | 6 |
| JAS20037 | 37 | | | |

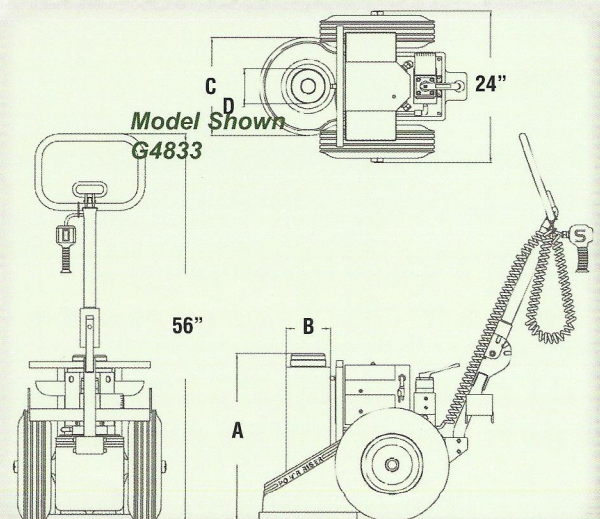

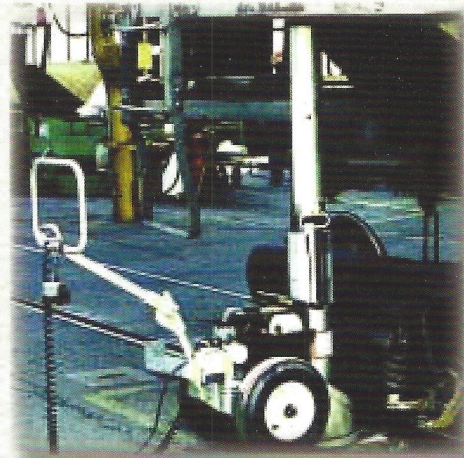

Simplex Pow'r-Risers™ are used to pick up the largest off road and railcars in the world. "We use the Simplex jack due to its easy transport and the many optional extensions and lock rings that ensures the level of safety required in mining operations."

JAS20037 SHOWN
SEE TABLE FOR ADDITIONAL MODELS

SIMPLEX POW'R-RISERS ARE THE IDEAL CHOICE FOR RAILCAR & OFF-ROAD EQUIPMENT JACKING

| Product Ordering & Specifications | | | | | | | | | | | | |
|-----------------------------------|-----------------|------------------|-------------|----------|---|------------------------|-----------------------------|------------------|-----------------------|----------------------------|----|-----|
| Model | Capacity (tons) | Min. Height (in) | Stroke (in) | Motor | Max. Additional Stack Ht. Using Optional Extension System | Control Valve | Power Source | Noise Level (Db) | Weight (lbs) | | | |
| JAG024 | 60 | 24 | 14 | Air | 32* | Manual | Air Motor 50 CFM 80 PSI | 89 | 390 | | | |
| JAG037 | | 37 | 27 | | | | | | 600 | | | |
| JEG024 | | 24 | 14 | Electric | | | 115 VAC 50/60 Hz 20 amps | 80 | 390 | | | |
| JEG037 | | 37 | 27 | | | | | | 600 | | | |
| JA10026 | 100 | 26 | 16 | Air | 21** | Manual | Air Motor 50 CFM 80 PSI | 89 | 510 | | | |
| JA10037 | | 37 | 27 | | | 600 | | | | | | |
| JAS10026 | | 26 | 16 | | | Remote 12' Pendant | | | 510 | | | |
| JAS10037 | | 37 | 27 | | | | | | 600 | | | |
| JE10026 | | 26 | 16 | Electric | | Manual | 115 VAC 50/60 Hz 20 amps | 80 | 510 | | | |
| JE10037 | | 37 | 27 | | | | 600 | | | | | |
| JEB10026 | | 26 | 16 | | | 230/460 VAC 3 Phase | 530 | | | | | |
| JEB10037 | | 37 | 27 | | | 620 | | | | | | |
| JAS15026 | | 150 | 26 | | | 15 1/2 | Air | 21** | Remote 12' Pendant | Air Motor 50 CFM 80 PSI | 89 | 570 |
| JAS15037 | | | 37 | | | 26 1/2 | | | | | | 708 |
| JE15026 | 26 | | 15 1/2 | Electric | Manual | 115VAC | 80 | | 570 | | | |
| JE15037 | 37 | | 26 1/2 | | | 708 | | | | | | |
| JEB15026 | 26 | | 15 1/2 | | 230/460 VAC 3 Phase | 590 | | | | | | |
| JEB15037 | 37 | | 26 1/2 | | 728 | | | | | | | |
| JAS20026 | 200 | 26 | 15 1/2 | Air | Contact Factory | Remote 12' Pendant | Air Motor 50 CFM 80 PSI | 89 | 640 | | | |
| JAS20037 | | 37 | 26 1/2 | | | | | | 825 | | | |

Note: To order 230VAC single phase units, add an "A" to the end of the model number.

* Based on (1) 18" and (1) 11" extension and (1) 3" spacer.

**Based on (1) 18" extension and (1) 3" spacer.

WARNING: Any two extensions may be stacked for loads up to 60 tons per jack.

For loads from 60 tons to 150 tons only 1 extension and 1 spacer can be used.

POW'R RISER

The Simplex Pow'r-Riser, When Used With The Extension Set and Spacer Set, Can Handle All Rail Cars and Off-Road Equipment Without Blocking.

- **Extensions** - Add extra height without utilizing piston stroke.

- **Spacers** - Fine tune your extension height in small increments.

- **Locking U-Rings** - Provides mechanical load holding and added safety.

- **Swivel Load Caps** - Distributes the load on center for non-perpendicular lifting.

EXTENSIONS



| Product Ordering & Specifications | |
|-----------------------------------|----------------------------|
| Model | Contents |
| JE5 | 5" Extender |
| JE7 | 7" Extender |
| JE9 | 9" Extender |
| JE11 | 11" Extender |
| JE14 | 14" Extender |
| JE18 | 18" Extender |
| ES6024 | 5", 7", 11", 18" Extenders |

SPACERS



| Product Ordering & Specifications | |
|-----------------------------------|------------------------|
| Model | Contents |
| JS1 | 1" Spacer - Qty. 2 |
| JS2 | 2" Spacer |
| JS3 | 3" Spacer |
| JS4 | (2) 1", 2", 3" Spacers |

(Use one extension & one spacer only for loads over 60 tons)
Use tallest extender on the bottom.
Fine tune your extension stack height by adding 1", 2" or 3" spacer.

SWIVEL LOAD CAP



| Product Ordering & Specifications | |
|-----------------------------------|--------------|
| Model | Description |
| JTS60 | 60 & 100 Ton |
| JTS150 | 150 Ton |
| JTS200 | 200 Ton |

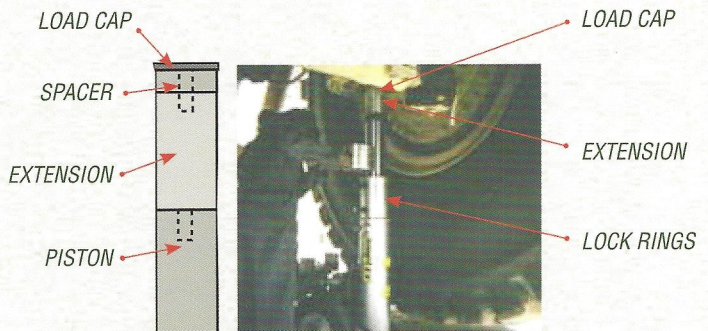

LOCKING U-RING SETS

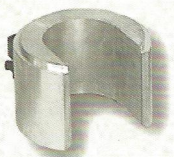

| Product Ordering & Specifications | | |
|-----------------------------------|------------------------|--|
| Model | Models Used On | Contents |
| JU110 | 60 & 100 Ton | 10" Extender |
| JU14 | 60 & 100 Ton | 4 1/4" Extender |
| JU13 | 60 & 100 Ton | 3" Extender |
| JU11 | 60 & 100 Ton | 1" Extender |
| JU1510 | 150 Ton | 10" Extender |
| JU155 | 150 Ton | 5 1/2" Extender |
| JU153 | 150 Ton | 3" Extender |
| JU151 | 150 Ton | 1" Extender |
| JUS126 | 60 Ton 24"/100 Ton 26" | (2) JU11 - 1", (1) JU13 - 3", (2) JU14 - 4 1/4" |
| JUS137 | 60 Ton 37"/100 Ton 37" | (2) JU11 - 1", (1) JU13 - 3", (2) JU14 - 4 1/4", (1) JU110 - 10" |
| JUS1526 | 150 Ton 26" | (2) JU151 - 1", (1) JU153 - 3", (2) JU155 - 5 1/2" |
| JUS1537 | 150 Ton 37" | (2) JU151 - 1", (1) JU153 - 3", (1) JU1510 - 10", (2) JU155 - 5 1/2" |
| JUS2026 | 200 Ton 26" | (2) JU201 - 1", (1) JU203 - 3", (2) JU205 - 5" |
| JUS2037 | 200 Ton 37" | (2) JU201 - 1", (1) JU203 - 3", (4) JU205 - 5" |

